

SURELOK™ TECHNICAL SPECIFICATIONS AND INSTALLATION GUIDE

The complete engineered solution
for Temporary Movement Joints

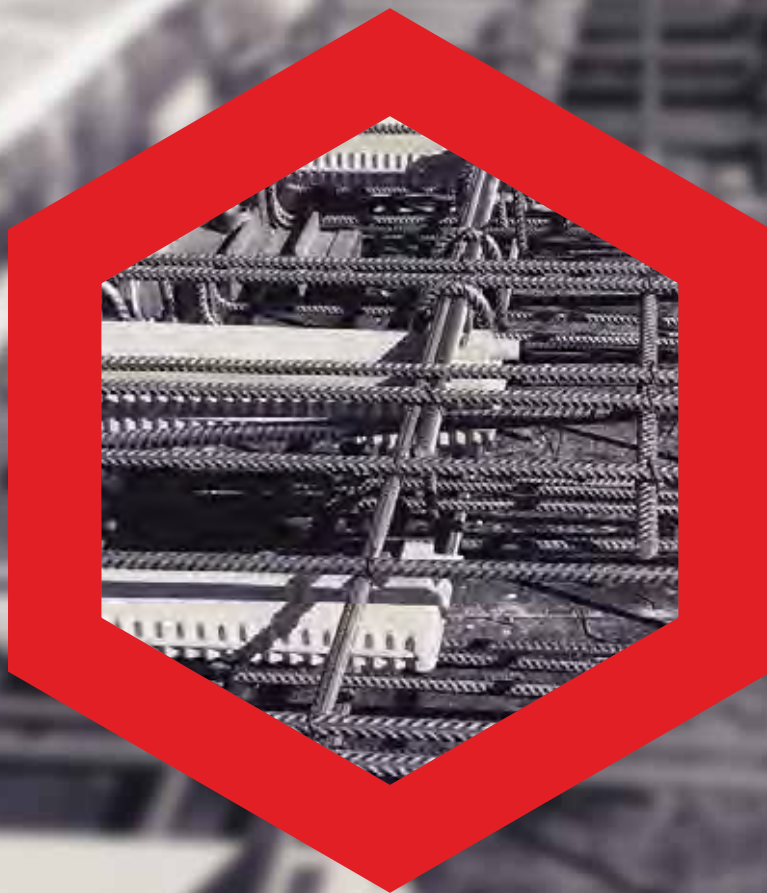

SureLok™



Cost effective, technical and practical solution.



Fully sealed system.



Fully grouted system for permanent locking.



Reduced site install time.



Vertical shear capacity without corbels.



Eliminates all corbels, edge-form drilling, and pre-grout sealing of joints.



An innovative advancement from all current market options.

Contents

Introduction	03	Components	08	Slab to Slab Reinforcement	12
SureLok™ Products	05	Performance	10	Slab to Wall Reinforcement	13
Applications	06	Dimensions	11	Installation Guides	14

SureLok™

Sealed and Locked

- SureLok™ is a revolutionary engineered solution to Temporary Movement Joints (TMJ).
- SureLok™ has been specifically designed to eliminate issues that current TMJ market options present.

SureLok™ is the result of years of experience, investment, research, development and testing. It has been developed for the post-tensioning, construction and mining industries with a patent pending in Australia and internationally.

SureLok™ is revolutionary as it offers a range of safety, cost, design and performance benefits. It is a world class leader in the industry as it is the first solution that provides bi-directional temporary movement and two-axis load transfer, all within a fully sealed component.

Temporary Movement Joints (TMJ) are the most complex joints in concrete slabs as they require temporary free movement in two horizontal directions prior to being locked tight for permanent stability and integrity of a structure. The solution required a combination of specialist areas of engineering outside of the standard field of structural engineering, using hydraulic engineering to design a movable pressure seal as well as elastomers and polymers to deliver affordability.

The SureLok™ solution engineers an intelligent void with a pressure sealed system bridging the joint whilst allowing two-way horizontal movement. When required, SureLok™

permanently locks the joint together with an approved grout mixture used for post-tensioned tendons. The intelligent void ensures the dowel retains cover for durability and fire within the sleeve across the joint without having to rely on the joint itself being sealed or grouted. Since 2011, over 12 stages of prototype development has been undertaken against rigorous design and site-performance criteria, complemented by product testing at both the University of Technology Sydney and the Western Sydney University.

SRG are extremely pleased and proud to have resolved the past long standing issues of temporary movement joint performance, whilst utilising the most appropriate constituent materials to deliver strong economic benefits for all applications.

You can now have peace of mind knowing that SureLok™ is the tested and proven solution to Temporary Movement Joints and is the answer to your TMJ needs and requirements.

The SureLok™ system now comprises two distinct ranges: one for Slab to Slab connections, and one for Slab to Wall connections, for a total of eight unique models.

Safety, quality, environment

Safety, Quality and the Environment are paramount to SRG. Being a customer focused organisation with an intense desire to be the best in our field, SRG operates and complies with the requirements of the following Quality Management, Environmental Management and Occupational Health & Safety Management Systems.

Occupational Health & Safety Management System

AS/NZS 4801:2001

OHSAS 18001

Quality Management System

ISO 9001:2008

Environmental Management System

AS/NZS ISO 14001:2004



PRODUCTS



The SureLok™ TMJ System Encompasses 8 Products

SureLok™ Slab to Slab

The SureLok™ Slab to Slab range encompasses two SureLok™ products. The **SureLok™ 200S** and the **SureLok™ 160S**.

The **SureLok™ 160S** was launched in 2014 as a TMJ (Temporary Movement Joint) product for Slab to Slab connections starting at a minimum slab depth of 160mm.

In 2016, SRG launched the **SureLok™ 200S** which is designed for slab depths of a minimum of 200mm and has been engineered to virtually eliminate any vertical displacement between slabs and to eliminate the need for long term back-propping.

SureLok™ Slab to Wall

The **SureLok™ 200W**, the **SureLok™ 160W**, the **SureLok™ 200BRS** and the **SureLok™ 160BRS** are designed to provide a TMJ between a slab and wall and eliminate the requirement for pour strips.

The **SureLok™ 200W** and **SureLok™ 160W** are used on applications where the anchor can be fixed inside the formwork and secured with a nailing plate and by local reinforcement. These systems are also used in precast walls.

The **SureLok™ 200BRS** and **SureLok™ 160BRS** are used for basement applications where the walls are applied using shotcrete.

SureLok™ Retrofit

The **SureLok™ 200R** and the **SureLok™ 160R** are post fixed retrofit systems. Both products are designed to provide a TMJ between a slab to wall or slab to slab where the bars need to be epoxied into an existing structure.

Legend:

S	Slab to Slab
W	Wall to Slab
BRS	Basement Retention System
R	Retrofit

SureLok™ Applications

SureLok™ SLAB TO SLAB

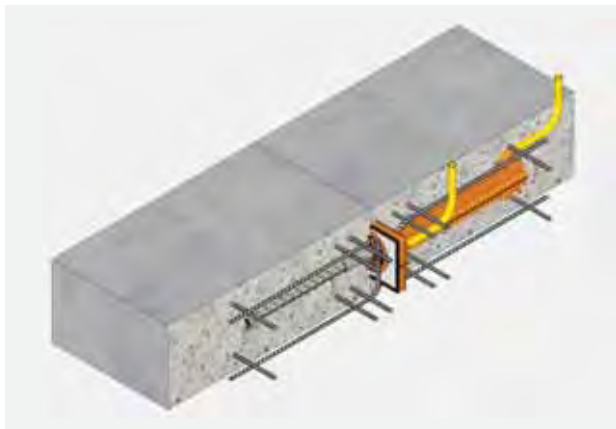

The SureLok™ Slab to Slab range includes two SureLok™ products. The **SureLok™ 200S** allows the back-propping to be removed when concrete strength achieves 32MPa, and the **SureLok™ 160S** is able to fit into slabs thinner than 200mm.

The **SureLok™ 200R** and the **SureLok™ 160R** are post fixed retrofit systems. Both products are designed to provide a TMJ between a slab to wall or slab to slab where the bars need to be epoxied into an existing structure.

SureLok™ SLAB TO WALL

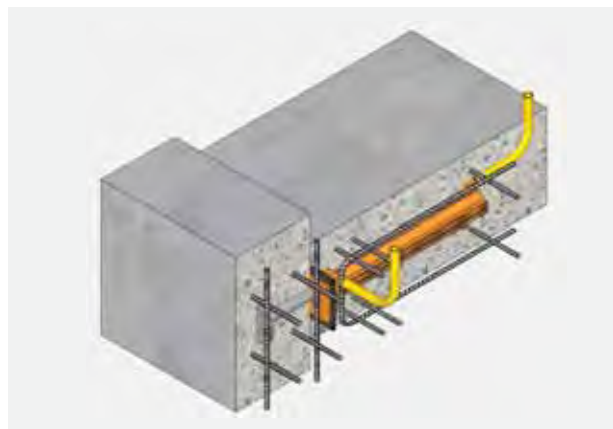

The SureLok™ Slab to Wall range encompasses four SureLok™ products. The **SureLok™ 200W**, the **SureLok™ 160W**, the **SureLok™ 200BRS** and the **SureLok™ 160BRS**. All four products are designed to provide a TMJ between a slab and wall and eliminate the requirement for pour strips.

The **SureLok™ 200W** and **SureLok™ 160W** are used in applications where the anchor can be fixed inside the formwork and secured with a nailing plate or by local reinforcement. These system are also used in precast walls.

The **SureLok™ BRS** systems are used for basement applications where the walls are applied using shotcrete.

The SureLok™ system encompasses 8 products

SureLok™	200S	160S	200W	160W	200R	160R	200BRS	160BRS
Propping can be removed prior to grouting	✓	✗	✓	✗	✓	✗	✓	✗
Slab to Slab connection	✓	✓	✗	✗	✓	✓	✗	✗
Slab to Wall connection	✗	✗	✓	✓	✓	✓	✓	✓
No pour strips	✓	✓	✓	✓	✓	✓	✓	✓
No corbels	✓	✓	✓	✓	✓	✓	✓	✓
Most economical TMJ	✓	✓	✓	✓	✓	✓	✓	✓
Simple installation	✓	✓	✓	✓	✓	✓	✓	✓
Reduced construction time	✓	✓	✓	✓	✓	✓	✓	✓
Improved job site safety	✓	✓	✓	✓	✓	✓	✓	✓
Slab thickness between 160 and 195mm	✗	✓	✗	✓	✗	✓	✗	✓
Slab thickness of 200mm and above	✓	✓	✓	✓	✓	✓	✓	✓
Suitable for existing structures	✗	✗	✗	✗	✓	✓	✗	✗



PRODUCTS



Slab to Slab Components

SureLok™ 200S

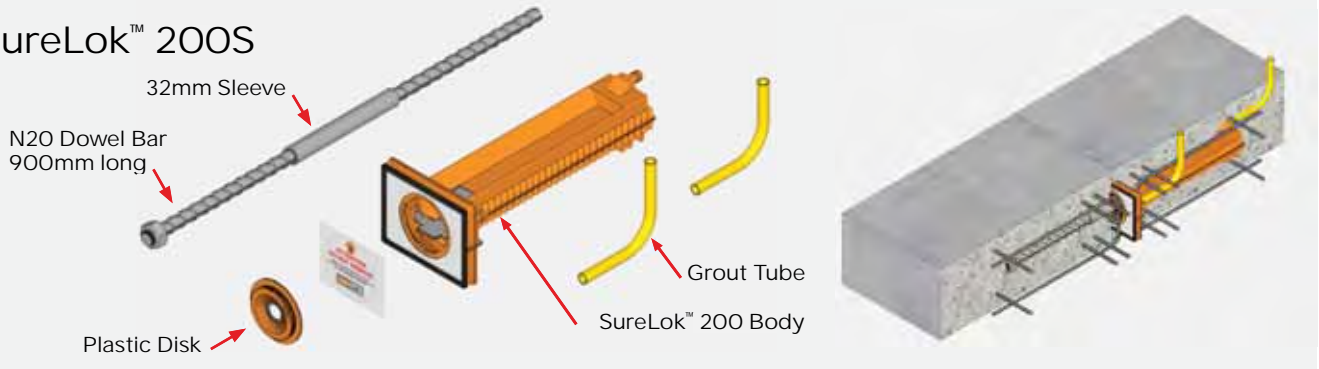

SureLok™ 200R

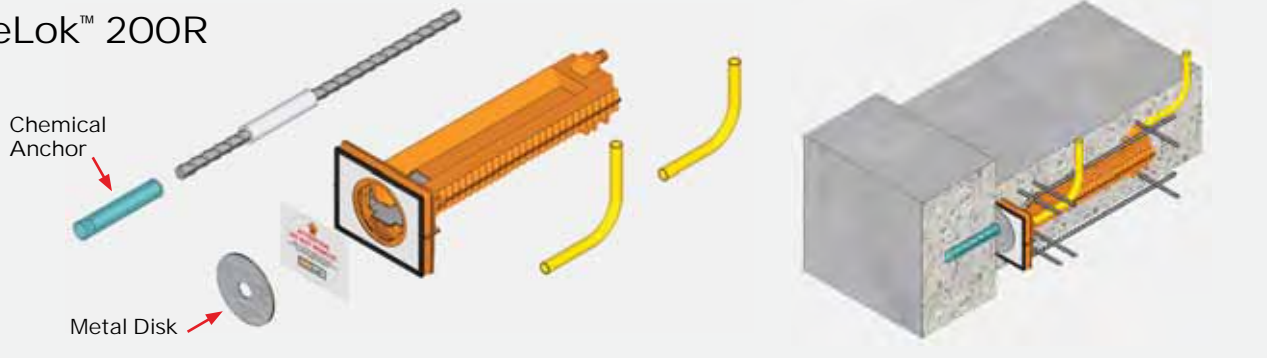

SureLok™ 160S

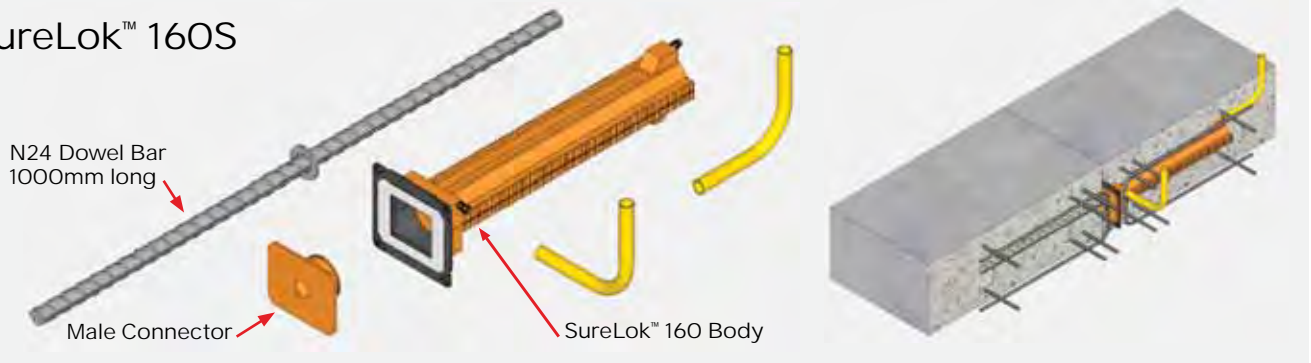

SureLok™ 160R

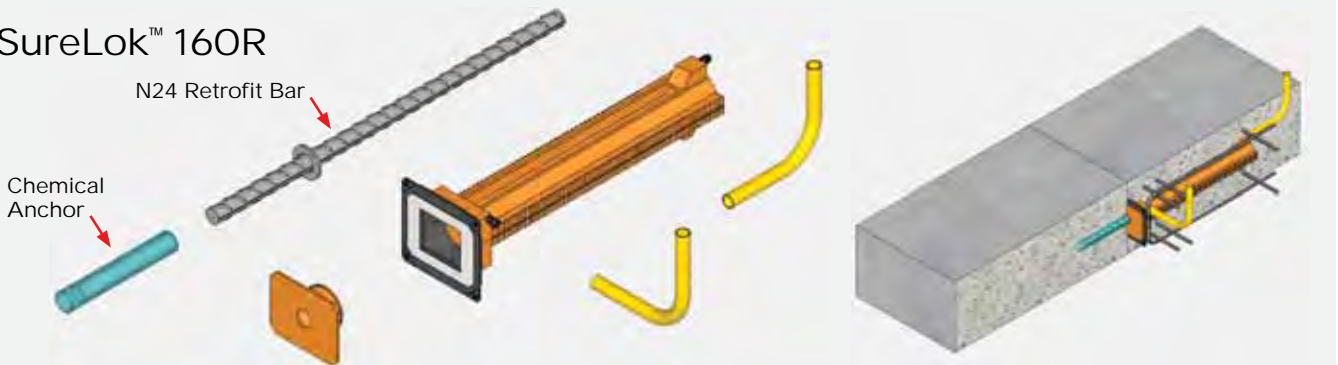

Slab to Wall Components

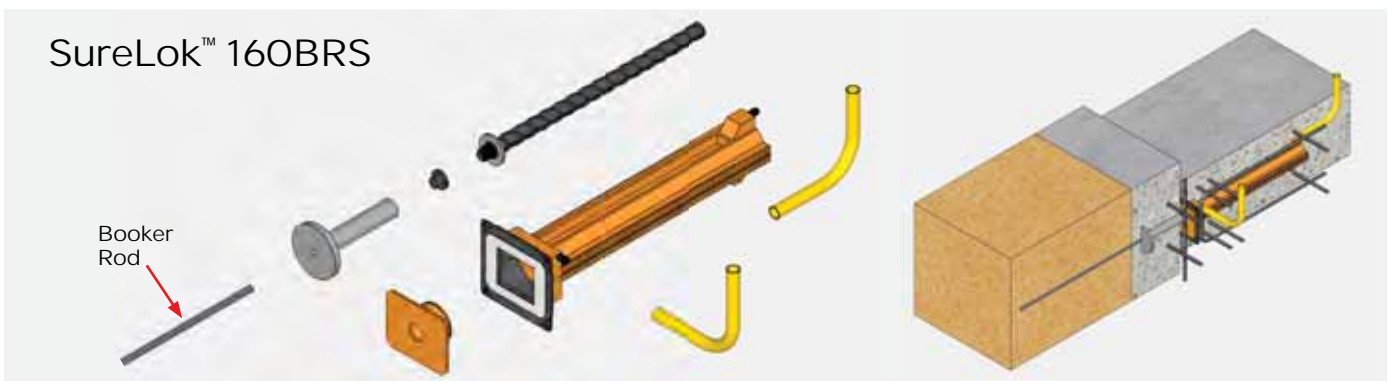
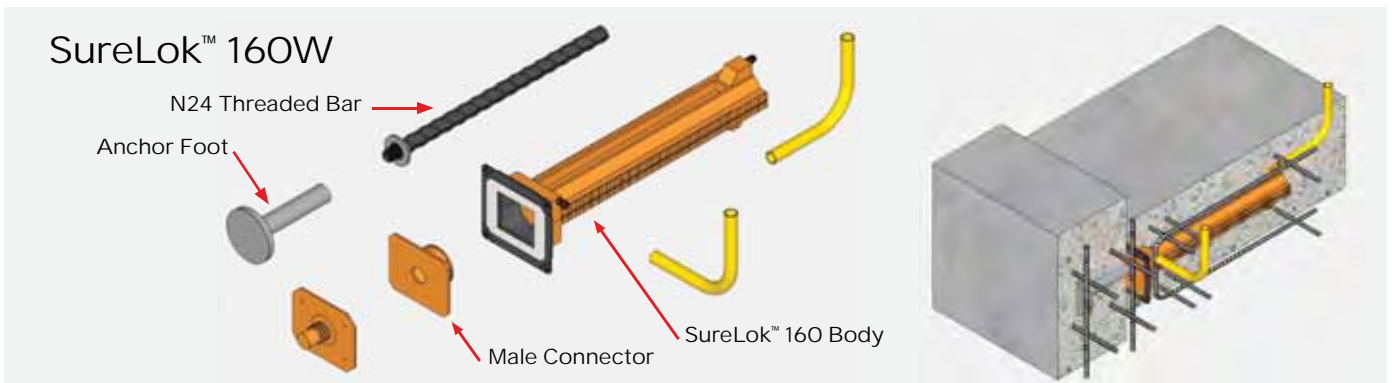
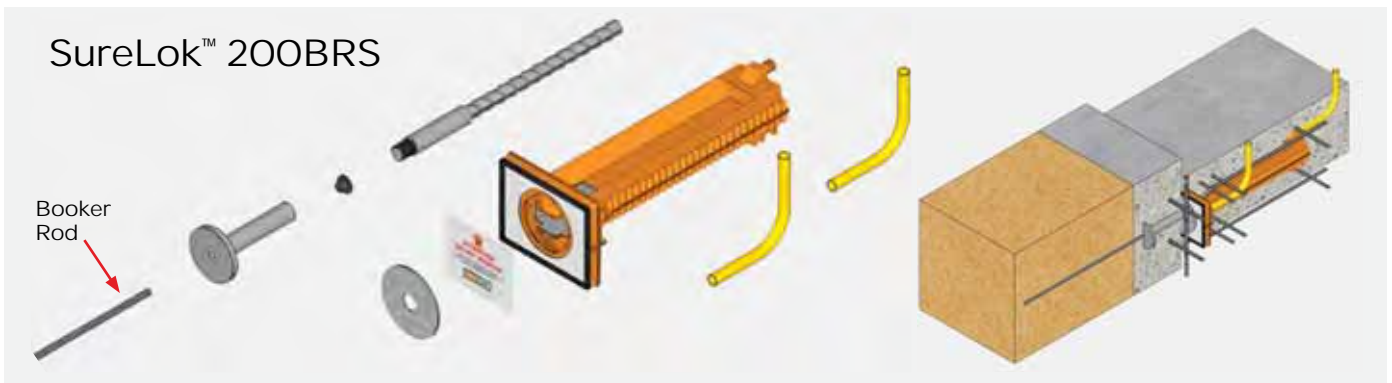
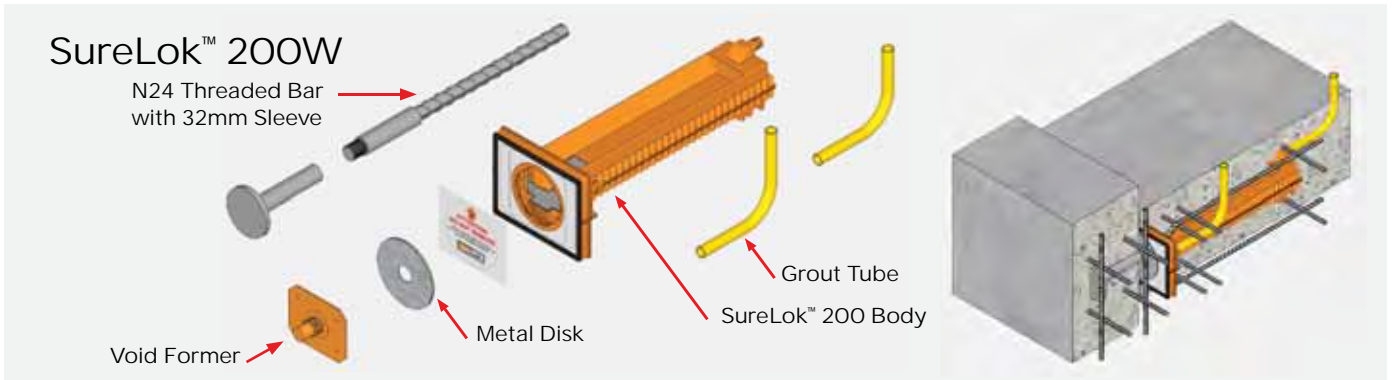

Performance

SureLok™ 200S, 200W, 200R, 200BRS

Combination shear & tension capacity table

SLAB THICKNESS (mm)	ULTIMATE TENSION (kN)	ULTIMATE - VERTICAL DESIGN RESISTANCE (kN) FOR VARYING JOINT WIDTHS							
		5mm	10mm	15mm	20mm	25mm	30mm	35mm	40mm
200	100	41	41	41	41	41	41	41	41
220	100	62	62	62	62	60	58	56	54
240	100	69	69	67	64	62	59	57	54
260+	100	76	73	70	67	62	59	57	54

Note: Shear capacities are the same in the ungrouted and grouted conditions.

SureLok™ 160S, 160W, 160R, 160BRS

Grouted shear only (no tension)

SLAB THICKNESS (mm)	ULTIMATE - VERTICAL DESIGN RESISTANCE (kN) FOR VARYING JOINT WIDTHS						
	5mm	10mm	15mm	20mm	25mm	30mm	
160	21	21	21	21	21	21	21
180	34	34	34	34	34	34	34
200	47	47	47	47	47	47	47
220	67	66	65	65	64	63	63
240	71	69	68	66	65	63	63
260+	75	72	70	68	65	63	63
VERTICAL DISPLACEMENT (mm)	SERVICE - VERTICAL DESIGN RESISTANCE (kN) FOR VARYING JOINT WIDTHS						
	5mm	10mm	15mm	20mm	25mm	30mm	
2mm	51	47	45	43	36	31	
4mm	64	60	56	51	47	42	

SureLok™ 160S, 160W, 160R, 160BRS

Grouted combination shear & tension

SLAB THICKNESS (mm)	ULTIMATE TENSION (kN)	ULTIMATE - VERTICAL DESIGN RESISTANCE (kN) FOR VARYING JOINT WIDTHS						
		5mm	10mm	15mm	20mm	25mm	30mm	
160	100	17	17	17	17	17	17	
180	100	29	29	29	29	29	29	
200	100	40	40	40	40	40	40	
220	100	60	60	59	57	56	54	
240	100	66	66	63	60	57	54	
260+	100	72	72	68	63	59	54	
VERTICAL DISPLACEMENT (mm)	SERVICE - VERTICAL DESIGN RESISTANCE (kN) FOR VARYING JOINT WIDTHS							
	5mm	10mm	15mm	20mm	25mm	30mm		
2mm	29	27	24	20	16	11		
4mm	47	46	42	40	38	36		

Grouted tension only

SLAB THICKNESS (mm)	ULTIMATE TENSION (kN)
160 and above	160

Notes:

1. All grouted capacities based on 32MPa concrete and 40MPa grout.
2. FOS of 1.7 used for the above shear capacities.
3. SureLok™ cover to N24 dowel bar is 20mm (with 40MPa grout).
4. Requires additional reinforcement for punching shear.
5. **SureLok™ 160R** and **200R** chemical anchor to be designed by others.

General qualification

- Engineers to satisfy themselves that SureLok™ is fit for purpose in the context of all design, installation and service risks and parameters.

Engineering qualification

- The horizontal load capacities of SureLok™ subject to AS 1530 / ISO 834 fire conditions may vary from those tabulated.
- Grouting and/or caulking of the open joint is required to protect SureLok™ and provide structural adequacy under all fire conditions.

Installation qualification

- Care must be taken to install the product strictly as per installation instructions. Product failure may result from incorrect installation or from damage experienced by the product during installation or concreting.

Dimensions

SureLok™ 200S, 160S, 200W, 160W, 200R, 160R, 200BRS, 160BRS

Edge distance and spacing

To utilise the full shear capacity of each unit, the following minimum spacing rules apply for concrete punching cone at 45°. No spacing requirement to achieve maximum tension capacity.

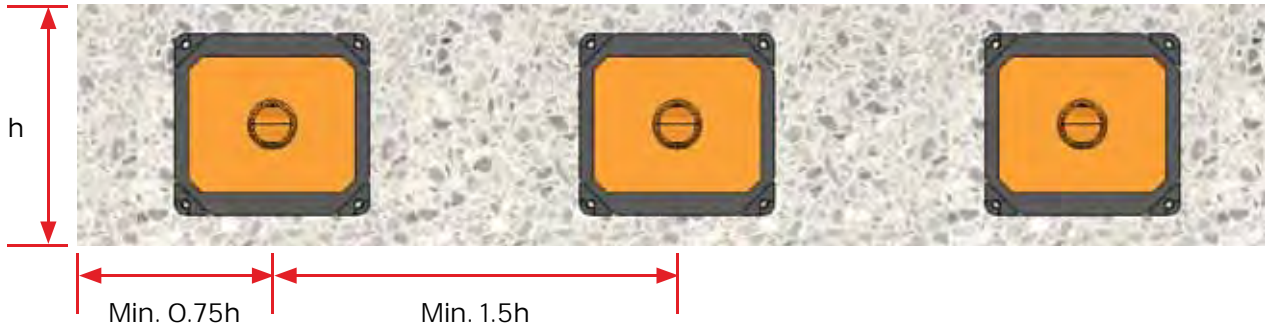

SureLok™ 200 Body Dimensions



SureLok™ 160 Body Dimensions

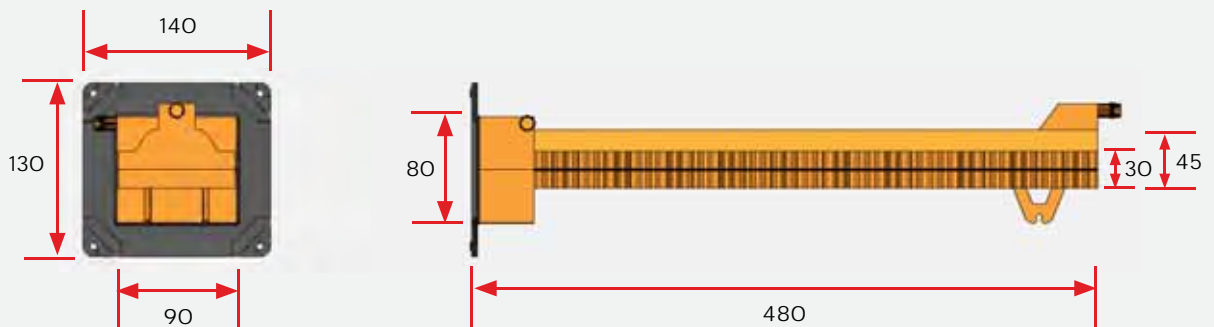

SureLok™ 160 and 200 relative joint movement

MODEL	JOINT RELATIVE MOVEMENT ALLOWANCE (max)	
	LATERAL (mm)	LONGITUDINAL (mm)
SL160 models	+/- 20	40
SL200 models	+/- 20	40

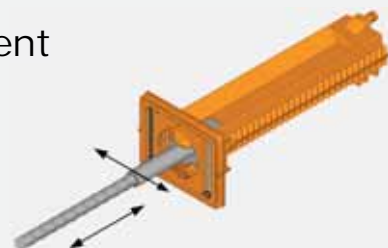

Slab to Slab Reinforcement

Each SureLok™ unit requires local reinforcement to ensure adequate performance capacity is achieved. Reinforcement must be detailed in accordance with relevant codes and the details shown below. Lacer bars can form part of the main edge reinforcement. U-bar quantities noted are required on both sides of the slab to slab joint.

SureLok™ 200S

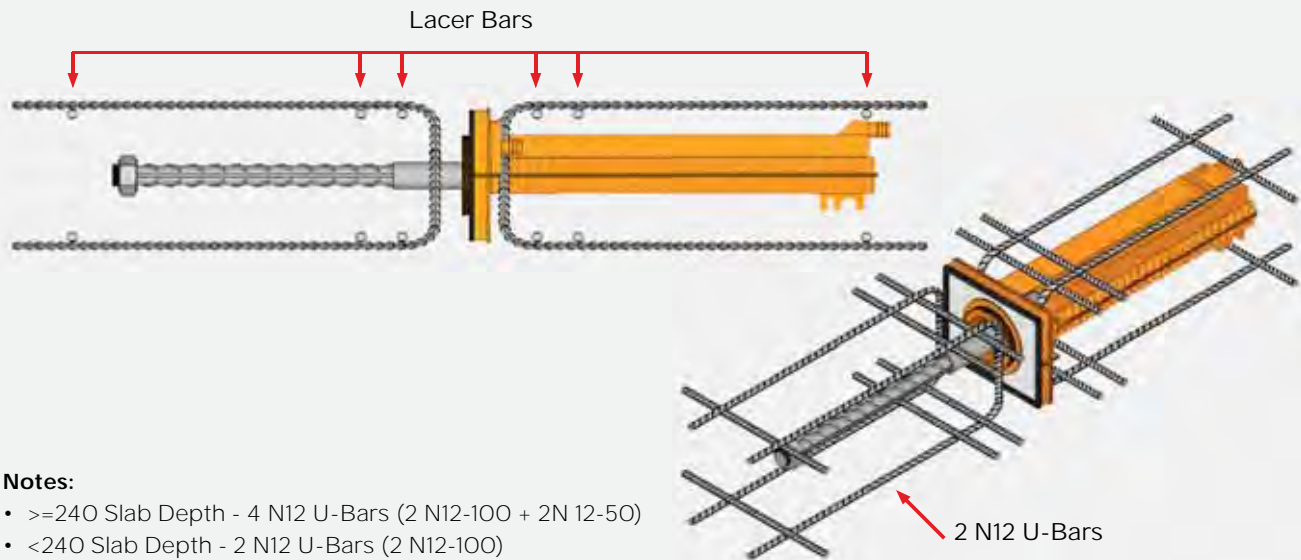

SureLok™ 160S

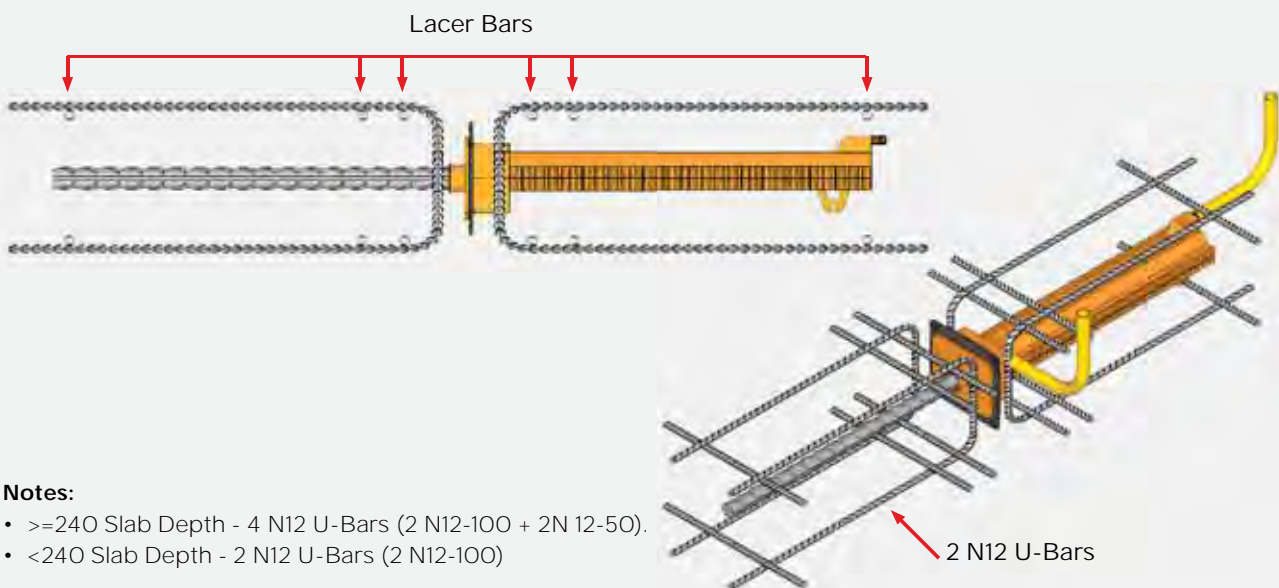

Slab to Wall Reinforcement

SureLok™ 200W, 200R, 200BRS

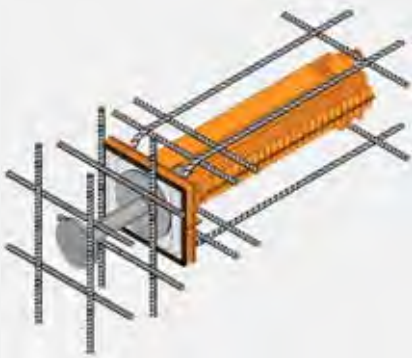

200W

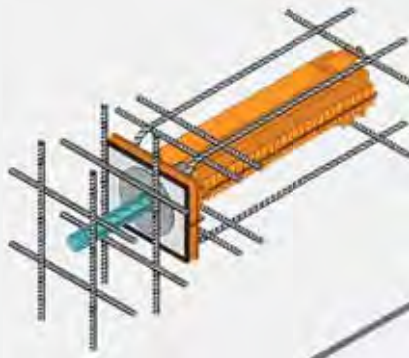

200R

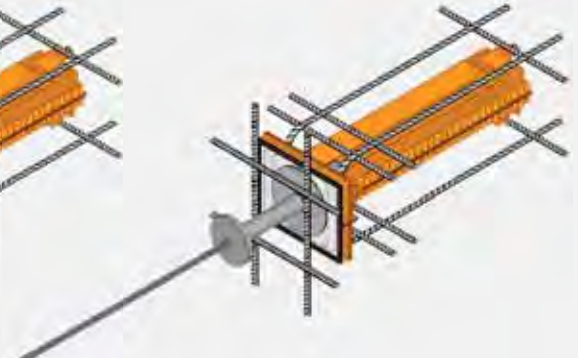

200BRS

SureLok™ 160W, 160R, 160BRS

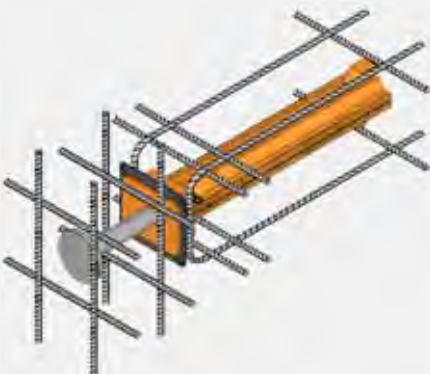

160W

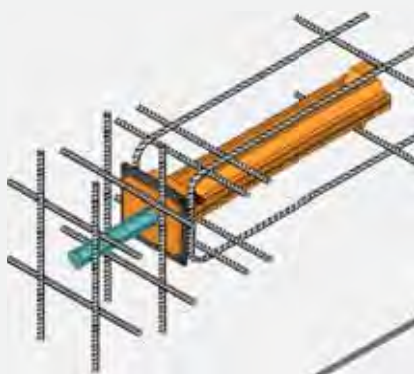

160R

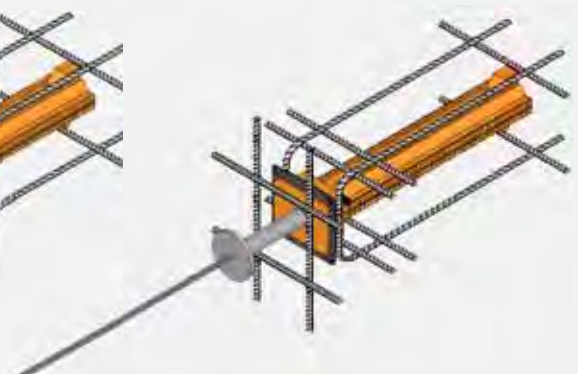

160BRS

Notes:

- Slab to Wall requires minimum wall reinforcement at 200 centres horizontal and vertical.

Installation Guides

SureLok™ 200S SLAB TO SLAB

POUR 1



1. Screw sleeve to formwork (using supplied screws ONLY) and chair ends or attach to reinforcement.



2. Fix the local reinforcement, as specified by engineer.

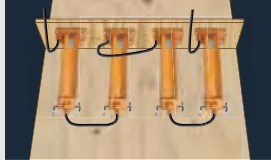

- 3a. Connect grout tubes (option 1) and pour concrete.
MAX 4 units together.

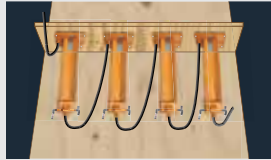

- 3b. Connect grout tubes (option 2) and pour concrete.
MAX 4 units together.

POUR 2



1. Remove formwork and remove circular protective sticker ONLY.



2. Attach male locking piece connector to sleeve by rotating clockwise by hand until locked.

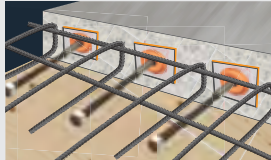

3. Insert dowel bar firmly and fix the local reinforcement around the dowel.

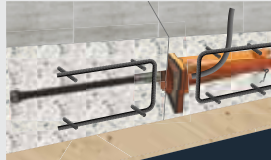

4. Pour concrete. Grout joint and SureLok™ sleeves as specified by engineer. Remove grout tubes.

SureLok™ 160S SLAB TO SLAB

POUR 1



1. Screw sleeve to formwork (using supplied screws ONLY) and chair ends or attach to reinforcement.



2. Fix the local reinforcement, as specified by engineer.



- 3a. Connect grout tubes (option 1) and pour concrete.
MAX 2 units together.



- 3b. Connect grout tubes (option 2) and pour concrete.
MAX 2 units together.

POUR 2



1. Pull off protective sticker



2. Install SureLok™ connector using Selleys Armour Flex as per sealing guide provided.



3. Install N24 dowel bar and reinforcement. Seal SureLok™ connector to dowel bar with duct tape.



4. Pour concrete. Grout joint and SureLok™ sleeves as specified by engineer. Remove grout tubes.

Notes:

1. Grout tubes can link or connect maximum 2 units together for grouting **SureLok™ 160S** or a maximum of 4 units together for grouting **SureLok™ 200S**. Always assess the risk of connecting multiple units together.
2. Grouting must be carried out under low pressure.
3. Each SureLok™ unit must utilise the 2 grout ports, one port as an inlet and the other as an outlet so as grout flows from one end of the unit to the other. Grout can flow in any direction along the SureLok™ unit.
4. Grout mix must achieve 40MPa to ensure the full tension capacity is achieved.

SureLok™ 200W SLAB TO WALL

POUR 1



1. Fix SureLok™ shear reinforcement to achieve full shear capacity as specified by engineer.
2. Apply grease to the plastic thread before screwing anchor foot onto fastened void formed ensuring full thread depth engaged, then re-apply grease to void former to allow easy release out of concrete wall. Pour concrete.

POUR 2



1. After wall formwork is removed, unscrew and discard void former.



2. Fit connector disk with seal over bar.

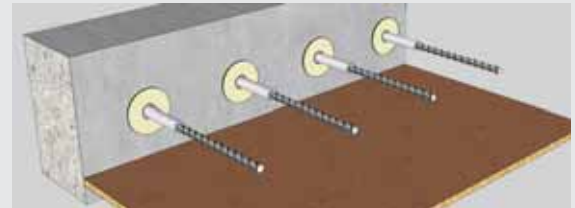

3. Screw bar with disk into foot anchor until hard against concrete.

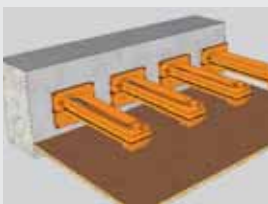

4. Remove adhesive seal protective layers from both the SureLok™ female plastic sleeve and the connector disk. Firmly push the plastic sleeve against the disk.

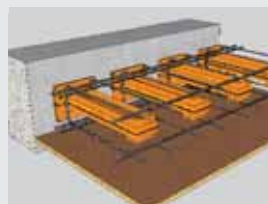

5. Fix SureLok™ shear reinforcement, to achieve full shear capacity as specified by engineer.

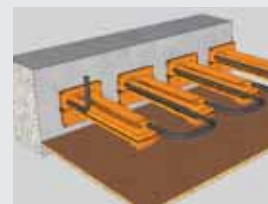

6. Connect grout tubes in series and pour concrete.

Max 4 units together.



7. Grout joint and SureLok™ sleeves as specified by engineer. Remove grout tubes.

Notes:

1. Grout tubes can link or connect maximum 4 units together for grouting. Always assess the risk of connecting multiple units together.
2. Grouting must be carried out under low pressure.
3. Each SureLok™ unit must utilise the 2 grout ports, one port as an inlet and the other as an outlet so as grout flows from one end of the unit to the other. Grout can flow in any direction along the SureLok™ unit.
4. Grout mix must achieve 40MPa to ensure the full tension capacity is achieved.

SureLok™ 160W SLAB TO WALL

POUR 1



1. Fix SureLok™ shear reinforcement, to achieve full shear capacity as specified by engineer.
2. Apply grease to the plastic thread before screwing anchor foot onto fastened void formed ensuring full thread depth engaged, then re-apply grease to void former to allow easy release out of concrete wall. Pour concrete.

POUR 2



1. After POUR 1 formwork removed, unscrew and discard void former.



2. Apply a sealant to the washer on the threaded side of the N24 dowel bar, before fitting the male connector piece.



3. Apply ArmourFlex around the lip of the male connector piece, before screwing in the fitted N24 dowel bar into the anchor.



4. Slide main sleeve over dowel bar ensuring full engagement onto male connector piece, then chair ends.



5. Fix SureLok™ shear reinforcement, to achieve full shear capacity as specified by engineer.



6. Connect grout tubes in series and pour concrete.

Max 2 units together.



7. Grout joint and SureLok™ sleeves as specified by engineer. Remove grout tubes.

Notes:

1. Grout tubes can link or connect maximum 2 units together for grouting. Always assess the risk of connecting multiple units together.
2. Grouting must be carried out under low pressure.
3. Each SureLok™ unit must utilise the 2 grout ports, one port as an inlet and the other as an outlet so as grout flows from one end of the unit to the other. Grout can flow in any direction along the SureLok™ unit.
4. Grout mix must achieve 40MPa to ensure the full tension capacity is achieved.

SureLok™ 200BRS BASEMENT RETENTION SYSTEM

SHOTCRETE

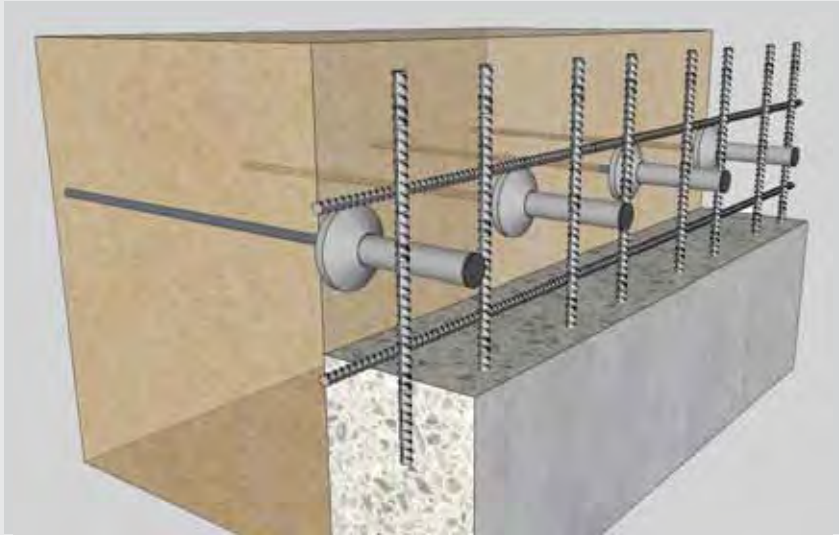

1. Mark location for foot anchor on the substrate wall.
2. Drill or drive in a 12mm booker rod into the substrate.
3. Screw the foot anchor onto the booker rod and adjust to final set point.
4. Shotcrete is applied exposing the rubber cap on the foot anchor.

POUR 1



1. After shotcrete is applied and wall finished, remove the rubber cap.

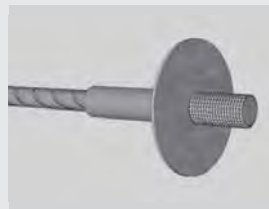

2. Fit connector disk with seal over bar thread.

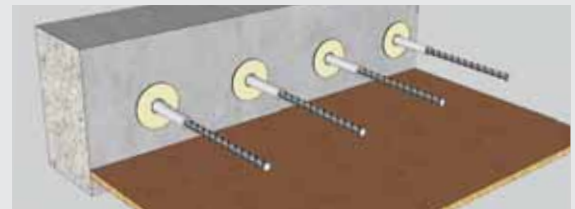

3. Screw bar with disk into foot anchor until hard against concrete.

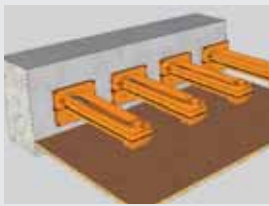

4. Remove adhesive seal protective layers from both the SureLok™ female plastic sleeve and the connector disk. Firmly push the plastic sleeve against the disk.

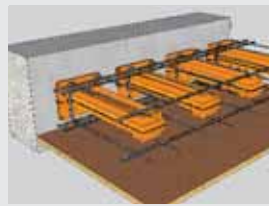

5. Fix SureLok™ shear reinforcement, to achieve full shear capacity as specified by engineer.

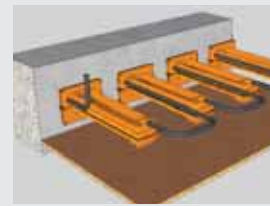

6. Connect grout tubes in series and pour concrete.

Max 4 units together.



7. Grout joint and SureLok™ sleeves as specified by engineer. Remove grout tubes.

Notes:

1. Grout tubes can link or connect maximum 4 units together for grouting. Always assess the risk of connecting multiple units together.
2. Grouting must be carried out under low pressure.
3. Each SureLok™ unit must utilise the 2 grout ports, one port as an inlet and the other as an outlet so as grout flows from one end of the unit to the other. Grout can flow in any direction along the SureLok™ unit.
4. Grout mix must achieve 40MPa to ensure the full tension capacity is achieved.

SureLok™ 160BRS BASEMENT RETENTION SYSTEM

SHOTCRETE

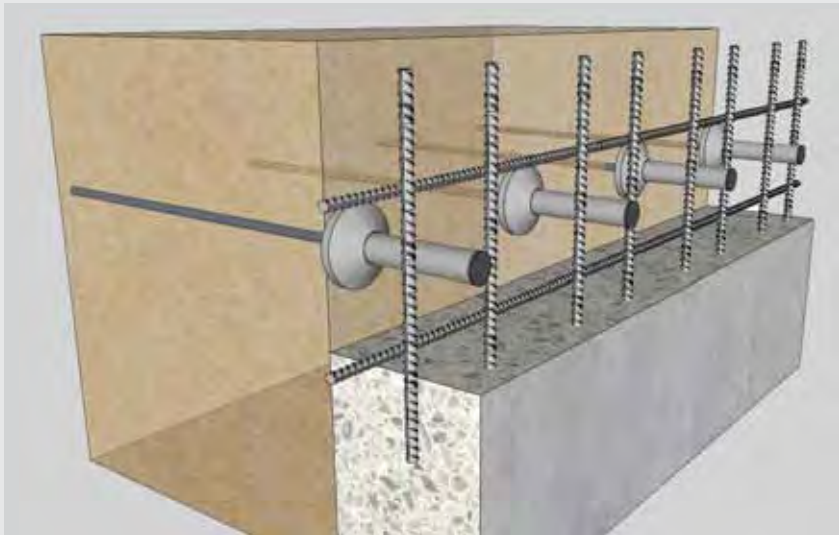

1. Mark location for foot anchor on the substrate wall.
2. Drill or drive in a 12mm booker rod into the substrate.
3. Screw the foot anchor onto the booker rod and adjust to final set point.
4. Shotcrete is applied exposing the rubber cap on the foot anchor.

POUR 1



1. After shotcrete is applied and wall finished, remove the rubber cap.

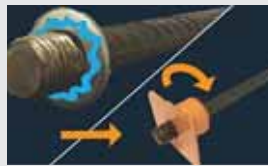

2. Apply a sealant to the washer on the threaded side of the N24 dowel bar, before fitting the male connector piece.



3. Apply ArmourFlex around the lip of the male connector piece, before screwing in the fitted N24 dowel bar into the anchor.



4. Slide main sleeve over dowel bar ensuring full engagement onto male connector piece, then chair ends.



5. Fix SureLok™ shear reinforcement, to achieve full shear capacity as specified by engineer.



6. Connect grout tubes in series and pour concrete.
Max 2 units together.



7. Grout joint and SureLok™ sleeves as specified by engineer. Remove grout tubes.

Notes:

1. Grout tubes can link or connect maximum 2 units together for grouting. Always assess the risk of connecting multiple units together.
2. Grouting must be carried out under low pressure.
3. Each SureLok™ unit must utilise the 2 grout ports, one port as an inlet and the other as an outlet so as grout flows from one end of the unit to the other. Grout can flow in any direction along the SureLok™ unit.
4. Grout mix must achieve 40MPa to ensure the full tension capacity is achieved.

SureLok™ 200R RETROFIT

DRILLING

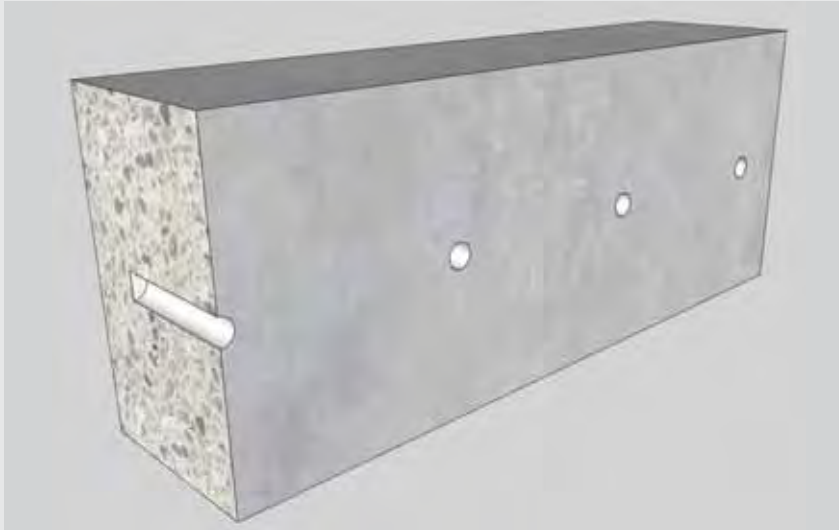

1. Drill holes in existing structure as per the epoxy supplier recommendations to suit the N24 SureLok™ Retrofit bar.
2. Prepare the holes as per the recommendations of the epoxy supplier.

POUR 1



1. Place epoxy in the holes as per the recommendations of the epoxy supplier.

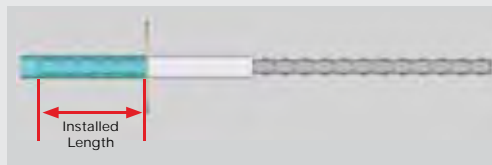

2. Insert the short length of the SureLok™ Retrofit bar through the central hole of the SureLok™ steel connector disk.

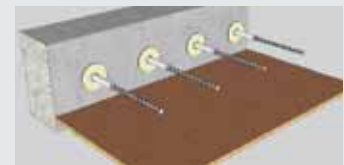

3. Insert the SureLok™ Retrofit bar with steel connector disk in the hole with epoxy, pressing the disk firmly against the concrete face.

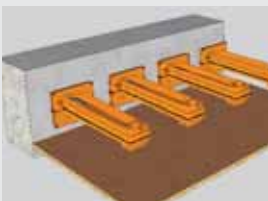

4. Remove adhesive seal protective layers from both the SureLok™ female plastic sleeve and the connector disk. Firmly push the plastic sleeve against the disk.

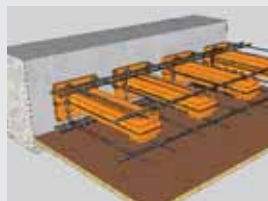

5. Fix SureLok™ shear reinforcement, to achieve full shear capacity as specified by engineer.

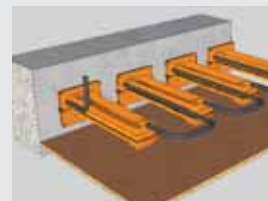

6. Connect grout tubes in series and pour concrete.
Max 4 units together.



7. Grout joint and SureLok™ sleeves as specified by engineer. Remove grout tubes.

Notes:

1. Grout tubes can link or connect maximum 2 units together for grouting. Always assess the risk of connecting multiple units together.
2. Grouting must be carried out under low pressure.
3. Each SureLok™ unit must utilise the 2 grout ports, one port as an inlet and the other as an outlet so as grout flows from one end of the unit to the other. Grout can flow in any direction along the SureLok™ unit.
4. Grout mix must achieve 40MPa to ensure the full tension capacity is achieved.

SureLok™ 16OR **RETROFIT**

DRILLING

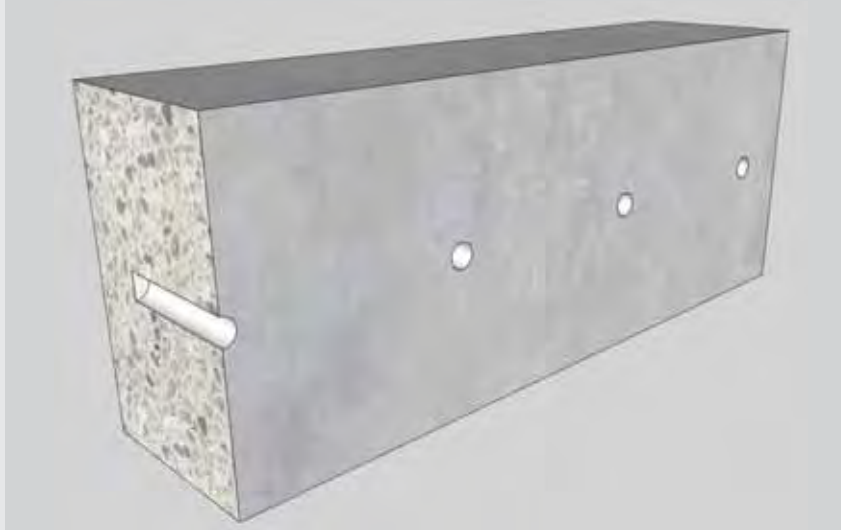

1. Drill holes in existing structure as per the epoxy supplier recommendations to suit the N24 SureLok™ Retrofit bar.
2. Prepare the holes as per the recommendations of the epoxy supplier.

POUR 1



1. Place epoxy in the holes as per the recommendations of the epoxy supplier.



2. Apply Armourflex to the washer on the short side of the N24 retrofit dowel bar, before fitting the male connector piece.



3. Apply ArmourFlex around the lip of the male connector piece before inserting the short end of the N24 Retrofit dowel bar into hole that has been previously filled with epoxy.

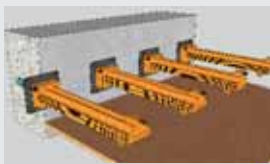
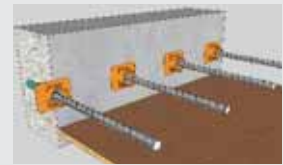

4. Slide main sleeve over dowel bar ensuring full engagement onto male connector piece, then chair ends.



5. Fix SureLok™ shear reinforcement, to achieve full shear capacity as specified by engineer.



6. Connect grout tubes in series and pour concrete.
Max 2 units together.



7. Grout joint and SureLok™ sleeves as specified by engineer. Remove grout tubes.

Notes:

1. Grout tubes can link or connect maximum 2 units together for grouting. Always assess the risk of connecting multiple units together.
2. Grouting must be carried out under low pressure.
3. Each SureLok™ unit must utilise the 2 grout ports, one port as an inlet and the other as an outlet so as grout flows from one end of the unit to the other. Grout can flow in any direction along the SureLok™ unit.
4. Grout mix must achieve 40MPa to ensure the full tension capacity is achieved.

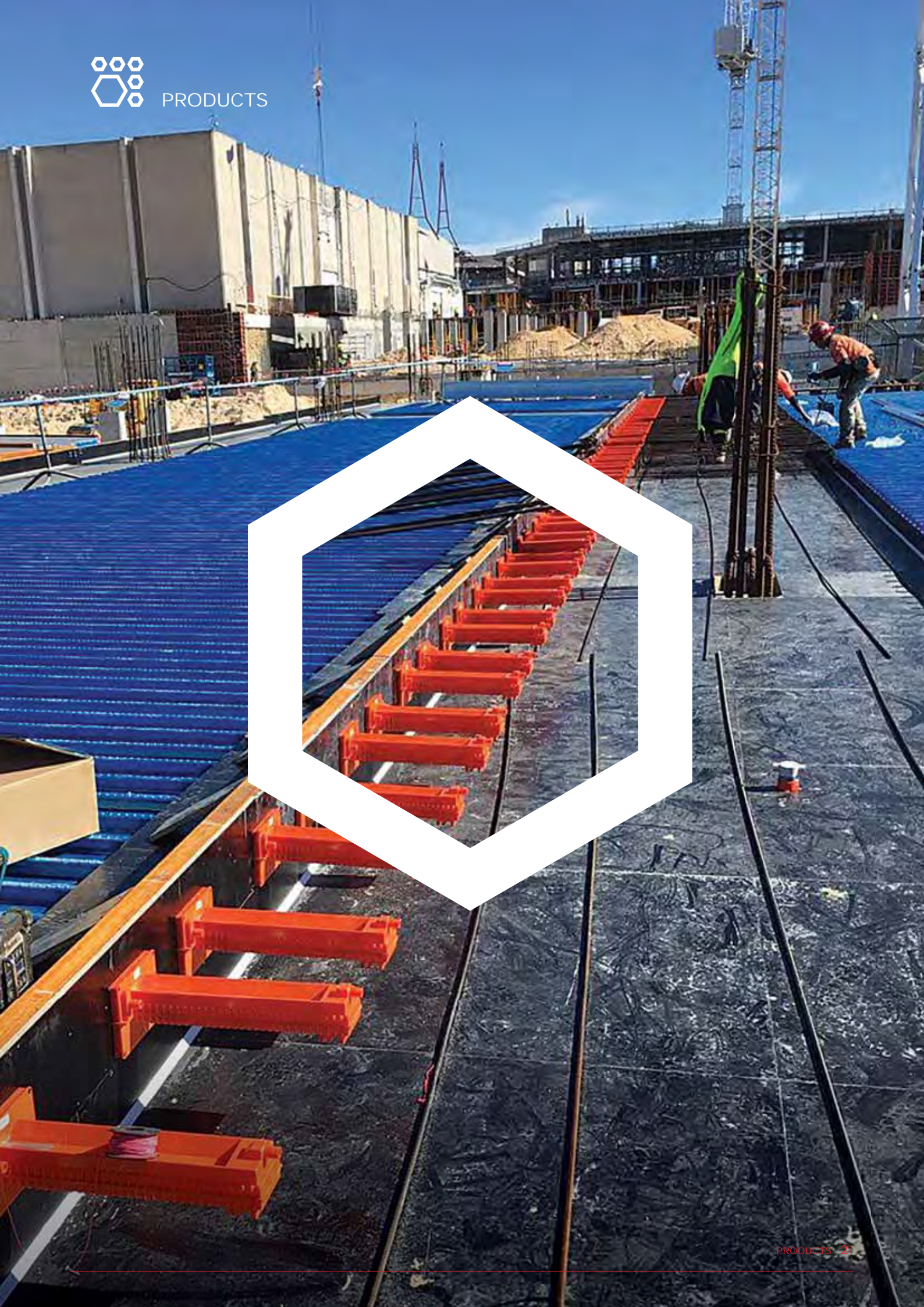





SURELOK™ THE COMPLETE ENGINEERED SOLUTION FOR TEMPORARY MOVEMENT JOINTS



Our global footprint

The information and details contained in this brochure are indicative and intended for marketing purposes only. They should not be relied upon as being complete and accurate. Prospective purchasers should make and rely on their own enquiries and a competent, experienced and qualified professional should always be consulted prior to using the product. SRG Global, its employees, agents and other representatives do not accept any responsibility or liability for any direct, indirect, consequential or other loss or damage suffered by any person arising out of or in connection with any reliance on the enclosed information. SRG reserves the right to amend or modify any information contained herein at any time and without notice. Any subsequent sale will be based on our terms and conditions.

srgglobal.com.au

CORPORATE HEAD OFFICE
Level 1, 338 Barker Rd
Subiaco WA 6008
+61 8 9267 5400
info@srgglobal.com.au

QLD
642 Old Gympie Rd
Narangba 3018
+61 7 3888 6655

WA
5 Riversdale Rd
Welshpool 6106
+61 8 9267 5400

VIC
2/290 Salmon St
Port Melbourne, VIC 3207
+61 3 9296 8100

NSW
S3/L1, 75 Carnarvon St
Silverwater, NSW 2128
+61 2 8767 6200

**MAKING
THE
COMPLEX
SIMPLE**